

Canon

ELPH 2

IXUS II



E

F

G

I

S

P

E English

G Deutsch

S Español

F Français

I Italiano

P Português

ADVANCED
PHOTO SYSTEM™

Handling Precautions

1. This camera is not resistant to water, and should not be used outdoors if it is raining or snowing. If it is accidentally dropped in water, contact an authorized Canon service facility. Keep the camera out of salt spray and excessive humidity. If used at the beach, clean it thoroughly afterward with a dry cloth.
2. Store the camera in a cool, dry, dust-free place. Be sure to keep the camera out of direct sunlight, and away from "hot spots" such as the trunk or rear window shelf of a car. Avoid places where mothballs are used, and use a desiccant in excessive humidity.
3. Do not attempt to disassemble the camera yourself, since there is high-voltage circuitry inside.
4. The battery may explode or cause burns if disassembled, recharged, shorted, exposed to high temperatures, or disposed of in a fire.
5. Use a blower brush to remove dust and sand from the lens and inside the camera. Do not apply any fluids to the lens or body. Take the camera to an authorized Canon service facility for a more thorough cleaning if necessary.
6. Film passing through X-ray examinations at an airport may be exposed and ruined even when loaded in the camera. Request a different method of inspection to avoid damage.
7. Color reproduction may be adversely affected if the film is left in the camera for a long time. Always develop exposed film promptly.

If you use the flash continuously (30 times or more) while no film is in the camera, the camera may stop to prevent the flash unit from overheating. If this happens, turn the camera off and wait a few minutes before turning it back on again.

This device complies with Part 15 of the FCC Rules. Operation is subject to the following two conditions: (1) This device may not cause harmful interference, and (2) this device must accept any interference received, including interference that may cause undesired operation.

Do not make any changes or modifications to the equipment unless otherwise specified in the instructions. If such changes or modifications should be made, you could be required to stop operation of the equipment.

This equipment has been tested and found to comply with the limits for a class B digital device, pursuant to part 15 of the FCC Rules. These limits are designed to provide reasonable protection against harmful interference in a residential installation. This equipment generates, uses and can radiate radio frequency energy and, if not installed and used in accordance with the instructions, may cause harmful interference to radio communications.

However, there is no guarantee that interference will not occur in a particular installation. If this equipment does cause harmful interference to radio or television reception, which can be determined by turning the equipment off and on, the user is encouraged to try to correct the interference by one or more of the following measures:

- Reorient or relocate the receiving antenna.
- Increase the separation between the equipment and receiver.
- Consult the dealer or an experienced radio/TV technician for help.

This digital apparatus does not exceed the Class B limits for radio noise emissions from digital apparatus as set out in the interference-causing equipment standard entitled "Digital Apparatus", ICES-003 of the Industry Canada.

Cet appareil numérique respecte les limites de bruits radioélectriques applicables aux appareils numériques de Classe prescrites dans la norme sur le matériel brouilleur: "Appareils numériques", NMB-003 édictée par l'Industrie Canada.



The CE Mark is a Directive conformity mark of the European Community (EC)

Thank you for purchasing this Canon product.
 Before taking pictures, please read these instructions carefully for a thorough understanding of how the camera operates.

Table of Contents

These instructions are divided into four sections: Introduction, Basic Operations, Advanced Operations, and Additional Information. When first using the camera, be sure to read the instructions from the Introduction.

Convention

The following convention is used in these instructions:



Warnings you should observe when using the camera.



Additional information on using the camera.

1	Introduction	
	Handling Precautions	2
	Table of Contents	4
	ADVANCED PHOTO SYSTEM Features	6
	Advanced Photo System Quick Reference	8
	Quick Reference	10
	Nomenclature	12
	Attaching the Strap	12
2	Basic Operations	
	1 Loading the Battery	15
	2 Loading the Film Cartridge	16
	Checking the Photography Data	17
	3 Turning the Power On	18
	Checking the Battery Power	18
	4 Holding the Camera	19
	5 Choosing the Print Type	20
	6 Using the Zoom	21

	7 Taking Pictures	22
	Green/Orange Indicators	23
	Taking Pictures through a Window	23
	Close-up Photography	24
	8 Removing the Film Cartridge	25
	Film Cartridge Processing	26
	Handling Film Cartridges After Exposure	26

3	Advanced Operations	
	Changing the Flash Mode	27
	1 (⚡) Auto Flash Without Red-eye Reduction	28
	2 (👁️⚡) Auto Flash With Red-eye Reduction	29
	Red-eye Reduction Function	30
	3 ⚡ Flash ON Mode	31
	4 ⚡ Flash OFF Mode	32
	5 (👁️⚡) Slow-synchro Mode with Red-eye Reduction	33
	Using Focus Lock	34
	🕒 Using the Self-timer	35
	📡 Shooting with the Optional Remote Control	36
	Replacing the Remote Control Battery	37
	Imprinting the Date and Time	38
	Selecting the Date Format	39
	Setting the Date and Time	40
	📄 Imprinting Titles	42
	Selecting the Title Language	42
	Selecting the Title	43
	🔄 Mid-roll Film Change	44
	To Remove an Unfinished Film Cartridge	44
	Loading a Partially Used Film Cartridge	45
	🖨️ Setting the Print Quantity	46
	Setting the Custom Functions	48
4	Additional Information	
	Troubleshooting	50
	Questions and Answers	51
	Specifications	52



ADVANCED PHOTO SYSTEM

Features

E

This camera supports the new Advanced Photo System. This system, as well as Canon's advanced technology has made it possible to produce a camera that is smaller than any previous camera with a 2x zoom lens.

Here are some of the special features of this system.

1 New Film

The IX240 new film comes in a compact film cartridge with no leader. This new drop-in film can be easily loaded by anyone, and replaces all previous hard-to-load films. In addition, the visual exposure indicator on the top of the cartridge shows whether the film cartridge is unexposed, partial, exposed, or processed.

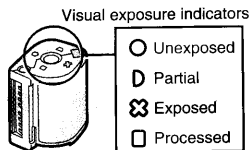

2 Mid-roll Film Change

If a partially exposed film cartridge is reloaded in the camera, the camera automatically advances the film to the next unexposed frame. You can then continue taking pictures until the film cartridge is fully exposed. This allows you to use separate film cartridges for different types of subjects, or moods.

*If a partially exposed film cartridge is loaded into a camera that does not support mid-roll film change, the camera will set the visual exposure indicator to "Exposed" and will not load the film. Be sure to check the features of each camera.

3 New Type Prints

The Advanced Photo System allows the camera to shoot three types of prints: in addition to classic print types (C print), you can now shoot wide-angle (H print) and panorama (P print) prints.

The Advanced Photo System can also imprint date/time information on the back of the print, or on the front and back of the print. The system can also imprint title text on the back of the print.

*Character size, shape, color, position, and ability to print on both sides may vary according to the individual photo shop.

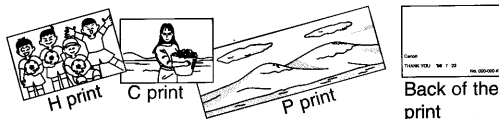

4 New Processing Methods

Previous 135 (35mm) film has always been returned from the processing lab as negative strips. This has made ordering reprints inconvenient since each picture must be found on the negative strips. With the Advanced Photo System however, the negative film is returned from the certified shop reloaded in its cartridge, accompanied by an index print. Unlike hard-to-see negative strips of previous cameras, this index print (where all shots can be viewed) makes reviewing prints much easier. Users can now order reprints simply by matching the ID on the back of the print or on the index print with the ID on the film cartridge, and then specifying the print number to be reprinted at the photo shop.

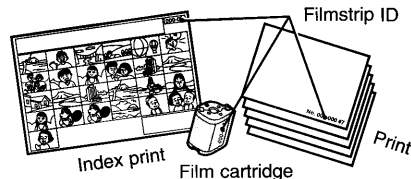

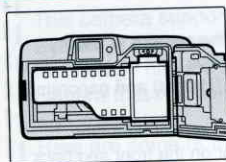

Previous film

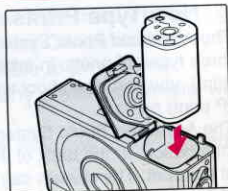

1 Simple film cartridge loading. (→ 16)

- Unlike previous 135 (35mm) film, there is no need to open the back cover and pull the film leader across.

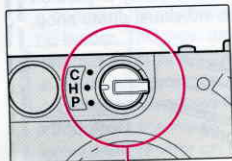

Print type selection lever



C print



H print

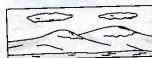

P print

2 A choice of print types (→ 20)

- You can choose from three print types.
 - C print: Classic print
 - H print: Wide-angle print
 - P print: Panorama print

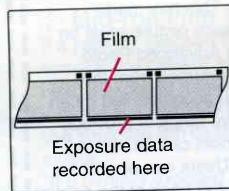

Film

Exposure data recorded here

Data recorded on film (example)

- Date and title
- Print type
- Print quantity
- Flash ON/OFF
- Subject brightness
- Etc.

3 A variety of data (IX information) is recorded magnetically on the film surface.

- All the information described at left can be recorded on the film.
- The exposure information is used in the printing process to produce better quality prints.

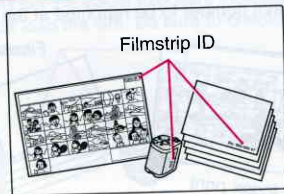

Filmstrip ID

4 Exposed film cartridges can be processed for printing at Advanced Photo System certified shops. (→ 26)

- After developing, the shop will return your pictures, along with an index print, and the film cartridge with the film inside.
- When ordering reprints from a certified shop, just match the ID on the back of the print or on the index print sheet with the ID on the film cartridge, and specify which prints you want.

Quick Reference

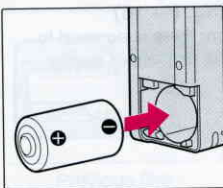

1 Load the battery. (→ 15)

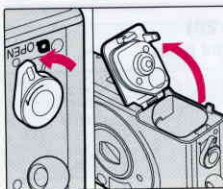

2 Open the film cartridge compartment cover. (→ 16)

- Turn the crank until the cover opens.

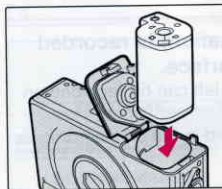

3 Drop in the film and close the cover. (→ 16)

- Check that the visual exposure indicator on the film cartridge shows either \bigcirc (unexposed) or D (partially exposed).

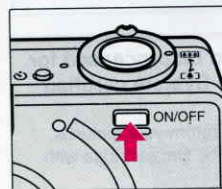

4 Switch the camera on. (→ 18)

- ➔ The lens cover opens and the lens is set for shooting.

For further details, refer to the page indicated.

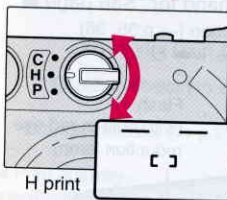

5 Choose the print type. (→ 20)

- ➔ The viewfinder field changes.

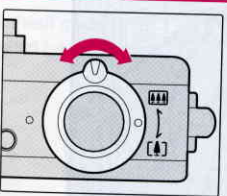

6 Turn the zoom lever to set the subject size. (→ 21)

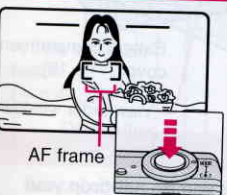

7 Position the AF frame over the subject and press the shutter button. (→ 22)

- ➔ The flash fires automatically in backlit or low-light conditions.

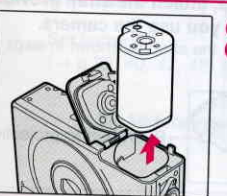



8 When you have finished the film and it has rewound, remove the film cartridge. (→ 25)

- Check that the \blacksquare icon on the LCD panel is blinking and then open the cartridge compartment cover.
- Remove the film cartridge and close the cartridge compartment cover.

Nomenclature

* (→ ■) is shorthand for "See page ■".

 Remote control/Self-timer button (→ p.35, 36)
Indicated in this document as  .

Shutter button (→ p.22)

Zoom lever
(→ p.21)

Flash
(with built-in red-eye
reduction lamp)

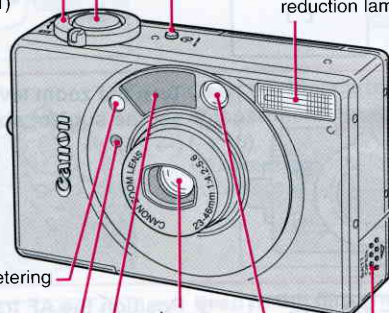

Light metering
window

Lens

Remote control
sensor

Battery compartment
cover (→ p.15)

AF emitter/sensor

Viewfinder window

Attaching the Strap

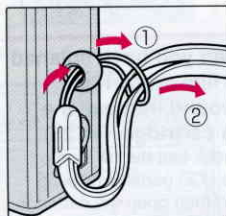

So that you do not drop your camera, attach the strap provided before you use the camera.

- Attach the strap as shown in steps ① and ②.



Push-button projection



- Use the push-button projection to push the SELECT button (→ p.40, 42, 47, 48), the SET button (→ p.39, 40, 47, 48) and the  button (→ p.25, 44).

LCD panel

Viewfinder (→ p.14, 20)

Green indicator (→ p.23)

Print type selection lever
(→ p.20)

Orange indicator (→ p.23)

 Print quantity
specification button (→ p.46)

Main switch (→ p.18)

 Flash mode
button (→ p.27)

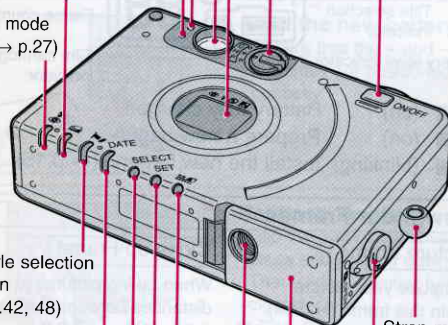

 Title selection
button
(→ p.42, 48)

Date button
(→ p.38, 40)

Select button
(→ p.40, 42, 47, 48)

Set button
(→ p.39, 40, 47, 48)

Strap mount
(→ p.12)

Film cartridge
compartment cover
crank (→ p.16, 25)

Film cartridge
compartment cover

Tripod socket

 Mid-roll change button (→ p.25, 44)

- Remote control (RC-5) is sold separately.

Nomenclature

* (→ ■) is shorthand for "See page ■".

☺ Remote control/Self-timer button (→ p.35, 36)
Indicated in this document as ☺ .

Shutter button (→ p.22)

Zoom lever
(→ p.21)

Flash
(with built-in red-eye
reduction lamp)

Light metering
window

Remote control
sensor

AF emitter/sensor

Lens

Battery compartment
cover (→ p.15)

Viewfinder window

Attaching the Strap

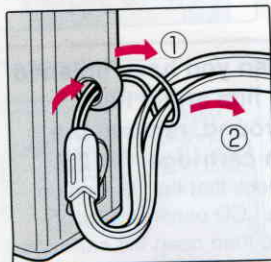

So that you do not drop your camera, attach the strap provided before you use the camera.

- Attach the strap as shown in steps ① and ②.

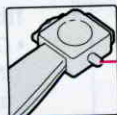

Push-button projection

- Use the push-button projection to push the SELECT button (→ p.40, 42, 47, 48), the SET button (→ p.39, 40, 47, 48) and the ☺ button (→ p.25, 44).

LCD panel

Viewfinder (→ p.14, 20)

Green indicator (→ p.23)

Print type selection lever
(→ p.20)

Orange indicator (→ p.23)

Print quantity
specification button (→ p.46)

Main switch (→ p.18)

Flash mode
button (→ p.27)

Title selection
button
(→ p.42, 48)

Date button
(→ p.38, 40)

Select button
(→ p.40, 42, 47, 48)

Set button
(→ p.39, 40, 47, 48)

Mid-roll change button (→ p.25, 44)

Strap mount
(→ p.12)

Film cartridge
compartment cover
crank (→ p.16, 25)

Film cartridge
compartment cover

Tripod socket

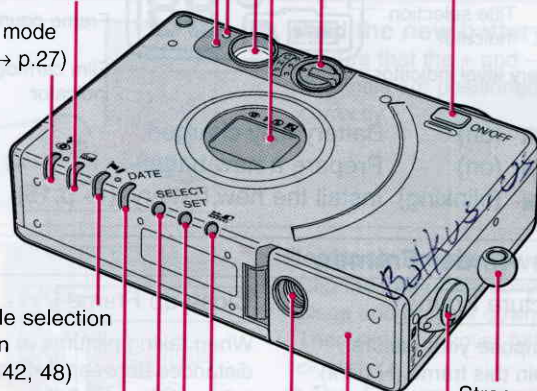

- Remote control (RC-5) is sold separately.

Nomenclature

LCD Panel (normally displays only the required information)

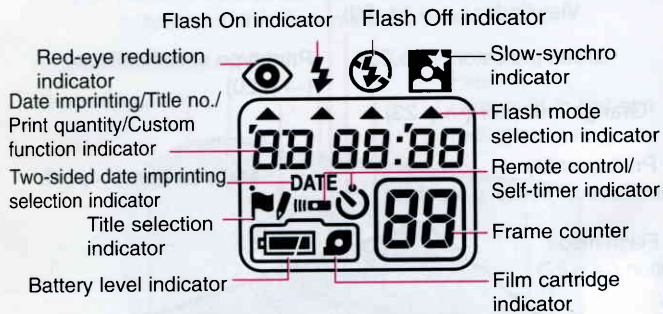

- (on) Battery fully charged
- (on) Prepare a new battery.
- (blinking) Install the new battery. (→ p.15)

Viewfinder Frames

Picture Frame

Compose your picture within this frame (H print).

Close-up Frame

When taking pictures at distances between 0.45 and 1.0 m (1.5 and 3.3 ft.), compose your picture below this frame. The area above this frame will not appear in the picture. (→ p.24)

AF Frame

Position this frame over the subject.

1 Loading the Battery

Applicable Battery: One CR2 lithium battery

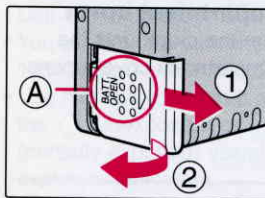

- 1 Open the battery cover.**
 - Push at **A** and slide the cover out until it stops **1**. Then slowly open the cover **2** and remove.

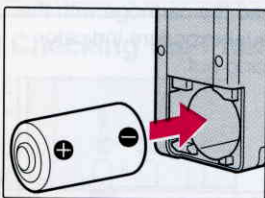

- 2 Load the new battery.**
 - Ensure that the + and - terminals are positioned correctly.

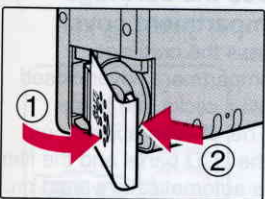

- 3 Reattach the cover.**
 - Clip the end of the cover in place and press it down **1**. Then slide the cover fully closed **2**.
 - ➔ The icon appears on the LCD panel and the date/time display "-- --" blinks.

- 4 Adjust the date and time.** (→ 40)

2 Loading the Film Cartridge

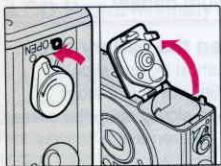

1 Open the film cartridge compartment cover.

- Turn the crank until the compartment cover opens.

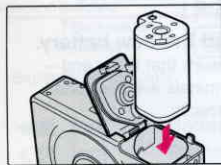

2 Load the film cartridge.

- Load the cartridge with the visual exposure indicator facing out.



3 Close the cartridge compartment cover.

- Press the cartridge compartment cover closed until it clicks into place.
➔ The  icon appears on the LCD panel and the film is automatically wound on.

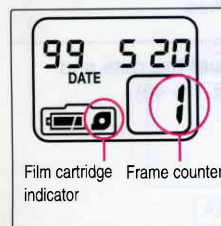



Film cartridge indicator Frame counter indicator

4 "1" appears on the frame counter.

- If "1" is not shown, check that the film cartridge is loaded correctly.
- When you load a film cartridge that is showing the  (partially exposed) indicator, the camera automatically advances the film to the first unexposed frame and from that point on the frame counter shows the total number of frames exposed.

About the Film Cartridges

- Use IX240 cartridge film.
- You cannot use conventional 135 (35mm) film in this camera.
- Use film cartridges that show the  (unexposed) or  (partially exposed) visual exposure indicators.

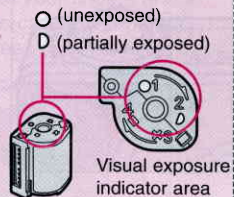

Checking the Photography Data

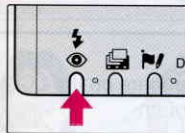

- With the camera switched off, press the  button.
➔ The information shown below appears on the LCD panel.





Film sensitivity



Maximum number of available shots.

- Film type
 - [n] : Color negative film
 - [r] : Color reversal film
 - [bl] : Black and white film
 - - : Other film



- If you load a film cartridge showing the  (fully exposed) or  (processed) indicator, "0" appears on the frame counter and the  icon blinks. Replace the film cartridge with one that shows the  (unexposed) or  (partially exposed) indicator.

3 Turning the Power On

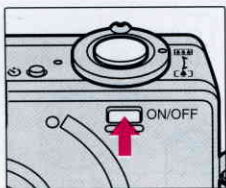

Press the main switch.



- ➔ The lens cover opens and the lens is zoomed out to the wide-angle setting (23 mm).
- ➔ The flash is set to automatic flash operation (Auto mode). (→ p.27, 28)
- If you press the main switch again, the lens retracts, the lens cover closes and the camera switches off.



• Be careful not to touch the lens.

Checking the Battery Power

Check that the battery icon  appears on the LCD panel when you switch the camera on.

-  (on) The battery is fully charged.
-  (on) Prepare a new battery.
-  (blinking) Install the new battery. (→ p.15)

A new battery generally has sufficient capacity for ten 25-shot film cartridges (based on Canon's Standard Test Method with normal temperatures and with the flash used for 50% of shots).



- Use one CR2 lithium battery.
- Always check the battery capacity before using the camera.
- If you are traveling or intend to take many pictures, take a supply of spare batteries. The batteries may be difficult to obtain at your destination.
- If you take a number of consecutive shots using the flash, the battery power may drop off temporarily and prevent the LCD panel from displaying data correctly. If this occurs, switch the camera off and wait a few minutes before switching it on again.

4 Holding the Camera

To avoid obscuring the image with your fingers and to ensure a clear sharp picture, take care to keep your hands and hair away from the areas marked • below.

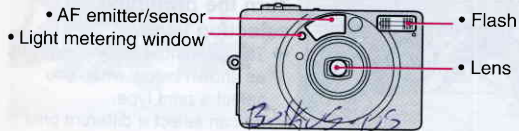

Hold the camera as shown below when taking pictures.

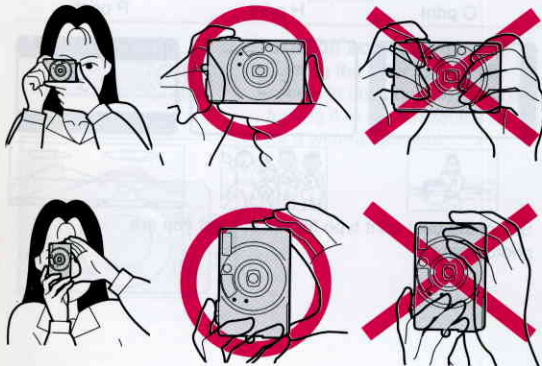

• Dust or soiling on the AF emitter/sensor causes focusing difficulties. Wipe soiled areas clean before taking pictures.

5 Choosing the Print Type

With this camera, you can choose any of three types of print: C print, H print or P print.

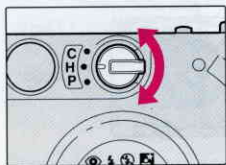

Turn the print type selection lever.

- ➔ The viewfinder screen changes as shown below when you select a print type.
- You can select a different print type for each shot.
- ➔ The black areas in the viewfinder do not appear on the print.

C print

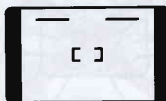

H print

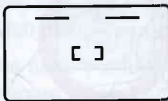

P print

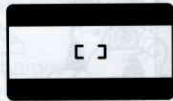

Select the best print type for the subject you are photographing.



- When you take pictures at distances between 0.45 and 1.0 m (1.5 and 3.3 ft.), the area above the close-up frame is not photographed. (→ p.14, 24)
- For P prints, ensure that you are at least 2 m (6.6 ft.) from your subject when you take the picture.

6 Using the Zoom

You can use the zoom lever to change the size of your subject.



Wide-angle (23 mm)

Use this setting for large-scale images such as scenery and group pictures.

Telephoto (46 mm)

Use this setting for pictures where you want to zoom in on your subject, such as portraits.

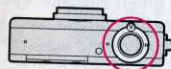

Turn the zoom lever.

- Turning the lever to the right zooms in on your subject, while turning it to the left zooms out for a wide-angle shot.

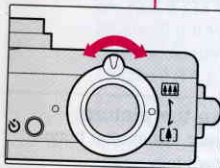

- When you switch the camera on, the lens is initially set to wide angle (23 mm).
- If the camera is left unused for 4 minutes with the lens extended to the telephoto position, the lens automatically retracts to the wide-angle position as a protective measure.

7 Taking Pictures

The shutter button has a two-step action. The first step sets the focus and exposure, while the second step releases the shutter.

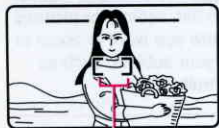
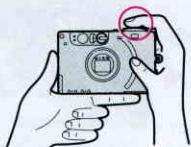

AF frame

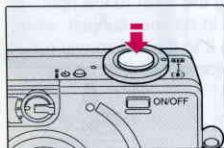

1 Set the focus.

- Position the AF frame over your subject and press the shutter button down halfway.
- ➔ The green indicator lights when the camera has focused on the subject.
- Keep the shutter button pressed down halfway.

2 Take the picture.

- Press the shutter button down fully.
- Press the button down gently and smoothly.
- ➔ The shutter is released.



- There is a very slight delay between the shutter button being pressed and the shutter releasing. In general, you should hold the camera still until you hear the film winding noise, which indicates that it has finished taking the picture.
- You can use the CF1 custom function setting to specify Realtime Release photography, in which the shutter is released instantly. (→ p.48, 49)

Green/Orange Indicators

When you press the shutter button down halfway, the indicators light or blink to show whether the camera is ready to shoot.

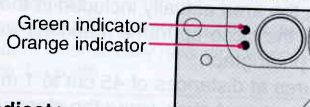

Green indicator

Lit: Camera ready to shoot (subject in focus).
Blinks (4 times/sec.): Proximity warning *1

Orange indicator

Lit: Flash fully charged.
Blinks (4 times/sec.): Camera shake warning (with the flash switched off) *2



- *1 • When the proximity warning appears, move away from the subject until the green indicator stops blinking and press the shutter button down halfway again. The proximity warning is given for distances of 25 cm (0.8 ft.) to 45 cm (1.5 ft.) for C and H prints, and 25 cm (0.8 ft.) to 2 m (6.6 ft.) for P prints. The green indicator may light for distances of less than 25 cm (0.8 ft.). Make sure that the subject is not too close to the camera.
- *2 • You should use a tripod or other camera mount when the camera shake warning appears.

Taking Pictures through a Window

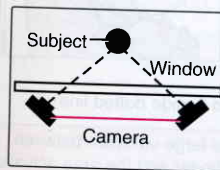

When you are taking pictures through a window, hold the camera as close to the glass as possible (20 cm (0.7 ft.) or less) and shoot at an angle to the glass.

If you are too far from the window, the camera may focus on the surface of the glass rather than on the subject.

Close-up Photography

When you are shooting at distances of 45 cm to 1 m (1.5 to 3.3 ft.), the area visible through the viewfinder does not match the area actually included in the shot. The area above the close-up frame markings will not be included in the photograph.

For taking pictures at distances of 45 cm to 1 m (1.5 to 3.3 ft.), follow the steps below, using the close-up frame.

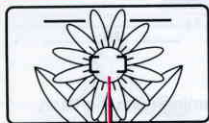

AF frame

- 1 **Set the focus.**
 - Position the AF frame over the subject and press the shutter button down halfway.
 - Check that the green indicator is lit.
 - Keep the shutter button pressed down halfway.

- 2 **Compose the shot and take the picture.**
 - Compose the shot so that the subject is below the close-up frame and take the picture.
 - Do not change the distance between the camera and the subject.

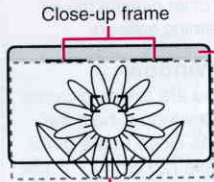

Area visible in the viewfinder but not photographed.

Area actually photographed (inside dotted line)







- For P prints, because of the large variation between the area visible in the viewfinder and the area actually photographed, shots should be taken from distances of at least 2 m (6.6 ft.).

8 Removing the Film Cartridge

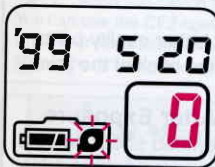
The film rewinds automatically when it reaches the end. The frame counter counts down as the film rewinds and the  icon blinks when the film is fully rewound.

- To remove the film cartridge before the end of the film is reached, see p.44.
- You can use the CF3 custom function setting to prevent the camera from automatically rewinding when it reaches the end of the film. (→ p.48)



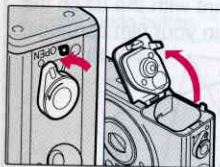

- 1 **Check that the  icon is blinking.**
 - If the  icon is not blinking, use the push-button projection (→ p.12) to press the  button (→ p.13).

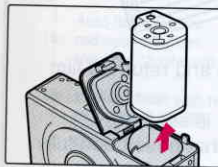

- 2 **Open the film cartridge compartment cover.**
 - Turn the crank until the cover opens.



- 3 **Take out the film cartridge.**
 - ➔ The  icon on the LCD panel goes off.
 - ➔ The visual exposure indicator on the film cartridge has changed to  (fully exposed).

Film Cartridge Processing

- Exposed film cartridges can be processed for printing at Advanced Photo System certified shops.
- All certified shops do the following:
 - Return your cartridge with the film inside.
 - Process all three types of prints.
 - Make an index print sheet.
 - Use the print quality data for better quality prints.
 - Imprint the date and title on the back of the print.

Handling Film Cartridges After Exposure

- When ordering reprints at a certified shop, be sure to match the ID number from the back of the print you want or from the index print with the ID on the film cartridge before handing in your film cartridge.

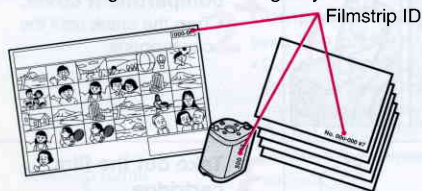

- Handle and store index prints and returned film cartridges carefully.
- The visual exposure indicator is set to ☒ (exposed) for film cartridges that have been fully exposed, and to ☐ (processed) for film cartridges that have been developed.
- Do not place cameras or film cartridges near televisions, speakers, or other sources of strong magnetic fields.

Changing the Flash Mode

You can switch the flash off or set it to fire each time you take a picture. Select the mode that best suits your subject and your surroundings.

- The (⚡) and (👁️⚡) settings can be stored in the camera's memory. At shipment, the camera is set so that the flash mode is (⚡) when you switch the camera on. However, if you switch the camera off while the flash mode is set to (👁️⚡), that setting is stored in the camera's memory and the flash mode will begin from (👁️⚡) when you switch the camera back on.
- You can use the CF2 custom function setting to specify that whichever flash mode is active when you switch off the camera should be stored in the camera's memory. (→ p.48)

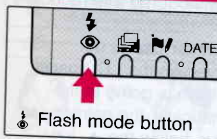

Select the flash mode.

- Each time you press the (👁️⚡) button, the black pointer ▲ at the top of the LCD panel moves to the next setting.
- Position the black pointer under the desired flash mode.
- ➔ For the Auto flash without red-eye reduction setting, the black pointer is not displayed.

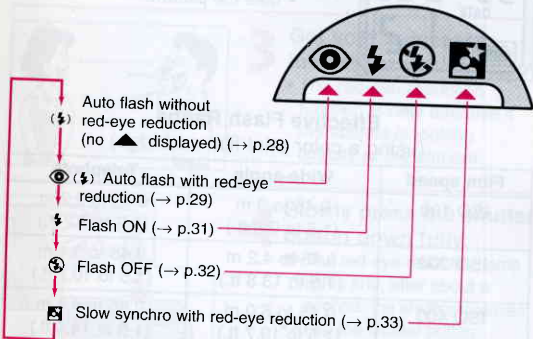

* When the (⚡) or (👁️⚡) flash mode is selected so that the flash fires automatically, the black pointer appears under the ⚡ icon when you press the shutter button down halfway.

1 (⚡) Auto Flash Without Red-eye Reduction

Use this mode to take pictures of subjects other than people, or to photograph people without using the red-eye reduction lamp. In this mode, the shutter releases immediately.

In backlit or low-light conditions, the flash fires automatically when you press the shutter button.

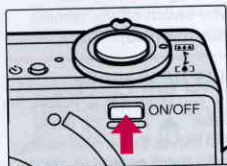

Switch the camera on.

- ➔ Set the flash mode to Auto flash without red-eye reduction (⚡).
- ➔ The pointer ▲ is not displayed on the LCD panel.
- ➔ If the flash is going to fire automatically, the pointer ▲ appears below the ⚡ icon when the shutter button is pressed down halfway.
- Take the picture.

Effective Flash Range

(using a color print film cartridge)

Film speed	Wide-angle	Telephoto
ISO 100	0.45 to 3 m (1.5 to 9.8 ft.)	0.45 to 2.2 m (1.5 to 7.2 ft.)
ISO 200	0.45 to 4.2 m (1.5 to 13.8 ft.)	0.45 to 3.1 m (1.5 to 10.2 ft.)
ISO 400	0.45 to 6.0 m (1.5 to 19.7 ft.)	0.45 to 4.4 m (1.5 to 14.4 ft.)

- If the pointer ▲ is displayed on the LCD panel, press the ⚡ button until the pointer disappears.

2 (👁️⚡) Auto Flash With Red-eye Reduction

Use this mode to reduce the red-eye effect when you are taking pictures of people in low-light conditions. When you press the shutter button, the red-eye reduction lamp lights and then the flash fires.

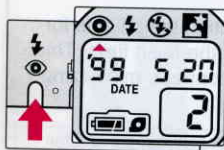

1 Set the flash mode to (👁️⚡).

- Press the ⚡ button until the pointer ▲ is below the (👁️⚡) icon on the LCD panel.

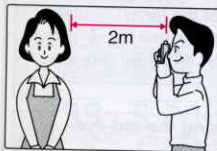

2 Move to within 2 m (6.6 ft.) of your subject.

- The effective range of the red-eye reduction lamp is 2 m.

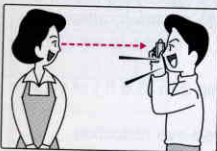

3 Get your subject to look at the camera.

- The red-eye reduction function is only effective if the subject is looking directly at the camera.

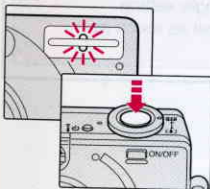

4 Slowly press the shutter button down fully.

- ➔ The red-eye reduction lamp lights and, after about a second, the shutter releases.
- Keep the shutter button pressed down until you hear the film advance to the next frame.

Red-eye Reduction Function

When you use the flash to take photos of people in low-light conditions, their eyes sometimes glow red in the photograph. This is referred to as the red-eye effect and is caused by the light of the flash being reflected off the retina.

In  mode, the red-eye reduction lamp lights for approximately 1 second before the flash fires. This causes the subject's pupils to contract, minimizing the risk of red-eye.



- When the red-eye reduction lamp lights, shutter operation is delayed for approximately 1 second to heighten the effectiveness of the lamp. To make the shutter operate immediately, use the  button to select (⚡) mode (→ p.28) and then take the picture.



Important guidelines for using the red-eye reduction function



1. Because this function is not effective unless the subject is looking directly at the lamp, attract the subject's attention so that he or she looks at the camera.
2. Take the picture from within 2 m (6.6 ft.) of your subject.
3. The effectiveness of the red-eye reduction function varies from person to person.
4. Set the lens to the wide-angle setting.
5. Raise the ambient light level as much as possible.

3 Flash ON Mode

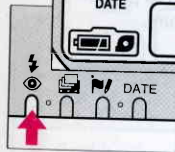
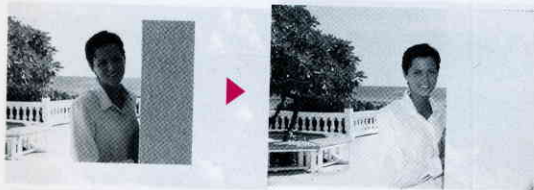
In this mode, the flash fires regardless of the light conditions when the picture is taken. Use this setting for fill-in flash in daylight or to soften the outline of the subject.



Set the flash mode to .

- Press the  button until the pointer  is below the  icon on the LCD panel.
- Take the picture.



Changing the Flash Mode

4 Flash OFF Mode

In this mode, the flash does not fire regardless of how dark conditions are when the picture is taken. Use this mode for sunset shots, for places where flash use is prohibited, or for available-light photography.



Set the flash mode to .

- Press the  button until the pointer  is below the  icon on the LCD panel.
- Take the picture.







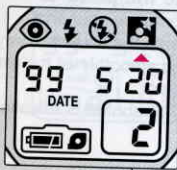

- Because a slow shutter speed is used (up to 2 seconds) when the flash is set to Flash OFF mode in low light conditions, take care to avoid camera shake.
- If the orange indicator is blinking (camera shake warning), set the camera on a steady surface or use a tripod.

5 Slow-synchro Mode with Red-eye Reduction

This function is useful when you are taking pictures of people against a sunset or nighttime background. The combination of slow shutter speed and flash illuminates the subject while still capturing the background.







Set the flash mode to .

- Press the  button until the pointer  is below the  icon on the LCD panel.
- After approximately 1 second, pointers appear under the  and  icons.
- Take the picture.



- Because a slow shutter speed (up to 2 seconds) is used in this mode, always use a tripod to prevent camera shake. Take care also to ensure that the subject does not move in the moment after the flash fires.



- The red-eye reduction function operates when the mode is set to .
- In some conditions,  mode (→ p.28) may give better results. For this reason, it is best to take the shot in both  mode and  mode.

Using Focus Lock

Lock the focus when you want the subject of your shot to be off to one side of the frame.

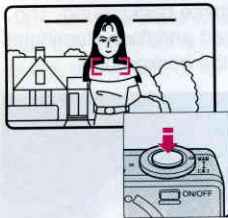

1 Lock the focus.

- Position the AF frame over the subject and press the shutter button down halfway.
- ➔ The green indicator lights when the subject is in focus.
- Keep the shutter button pressed down halfway.

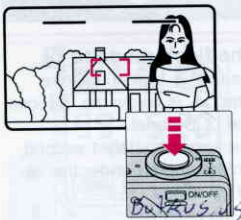

2 Compose the shot and take the picture.

- Compose your shot.
- Press the shutter slowly and smoothly all the way down.
- ➔ The shutter is released.



- Take care that the distance from the camera to the subject does not change. If the distance does change, lock the focus again.



- When you are shooting in Self-timer/Remote Control mode, you can lock the focus (step 1) and it remains locked for approximately 4 minutes after you release the shutter button. This gives you time to set the focus beforehand, compose the shot, and then take the picture.

Using the Self-timer

The self-timer function allows you to take a picture when you are some distance from the camera.

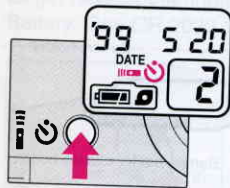

1 Set the mode to Self-timer.

- ➔ Press the button.
- ➔ The icon appears on the LCD panel.
- If you press the button again, the disappears and Self-timer mode is cancelled.

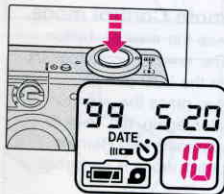

2 Compose the picture and press the shutter button.

- ➔ The red-eye reduction lamp flashes (once a second) and a 10-second countdown is displayed on the LCD panel.
- ➔ The shutter is released after about 10 seconds.
- To cancel the self-timer, press the button.



- Do not stand directly in front of the camera when you press the shutter button as this will result in the picture being out of focus.



- Approximately 2 seconds before the shutter is released, the lamp begins to flash more rapidly. If the flash and the red-eye reduction function are used, the lamp stays lit for the last 2 seconds.
- Self-timer shots can be taken for the 4 minutes that the icon is displayed.
- Set the camera on a steady surface or use a tripod.
- The Focus Lock function can be used in the same way as in normal photography. (→ p.34)

Shooting with the Optional Remote Control

Use the remote control to release the shutter from up to 5 m (16.4 ft.) in front of the camera.

Remote Control (RC-5)

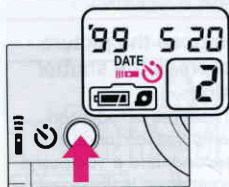
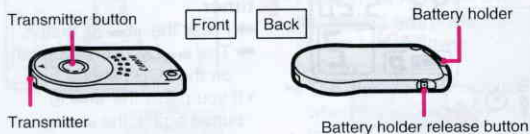

1 Set the camera to Remote Control mode.

- Press the button.
- The icon appears on the LCD panel.
- If you press the button again, the disappears and Remote Control mode is cancelled.

2 Take the picture.

- Lock the focus and then compose your shot. Then point the remote control transmitter towards the sensor on the camera and press the transmitter button.
- The red-eye reduction lamp blinks once a second (or remains lit when red-eye reduction is used) and a countdown is displayed on the LCD panel to show that the camera has received the signal from the remote control.
- The shutter is released approximately 2 seconds later.

Replacing the Remote Control Battery

Replace the battery when the remote control will no longer release the shutter.

Battery: One CR 2032 3V lithium battery

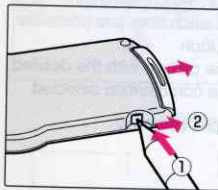

1 Pull out the battery holder.

- Use a pen or other pointed implement to push in the release button as you slide the battery holder out.

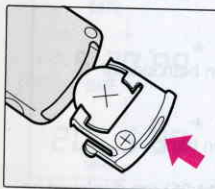

2 Load a new battery into the holder and fit the holder back into the remote control.

- Ensure that the + and - terminals are positioned correctly.



- Remote control photography may not be possible if the remote control sensor on the camera is exposed to sunlight or strong fluorescent light. In such situations, use the self-timer to take the picture, or move the camera to another location.
- The camera's remote control function may not operate correctly if the camera is close to a fluorescent light during signal reception. If this occurs, move the camera away from the fluorescent light.



- Remote control shots can be taken for the 4 minutes that the icon is displayed.
- Set the camera on a steady surface or use a tripod.
- The Focus Lock function can be used in the same way as in normal photography. (→ p.34)

Imprinting the Date and Time

The date and time can be imprinted on the back or on both sides of your photograph.

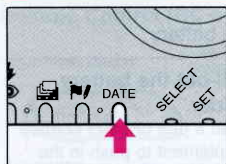

Select the date/time combination.

- The date/time combination changes each time you press the DATE button.
- Shoot the picture with the desired date/time combination selected.

Date/time combination display

'99 5 20 DATE	Date only (imprinted on both sides)
20 14:25 DATE	Date + time * (imprinted on both sides)
20 14:25	Date + time * (imprinted on back)

*: Only the day, hour and minute (20 14:25) are displayed on the LCD panel, but the imprinted data will show a combination of hours, minutes, and the date in the selected date format (Year-Month-Day, Month-Day-Year, or Day-Month-Year). (Ex. "'98 5 20 14:25".)



- **Note that the imprinting position, character size, font and color, and the availability of both-side imprinting vary depending on the store selected for processing and printing.**
- The date, time and title do not appear on the film negative but are imprinted when the prints are made, using the data magnetically recorded on the film by the camera (IX data).
- In addition to the date and time, the data imprinted on the back of each photo includes the film cartridge ID number and the frame number.

Selecting the Date Format

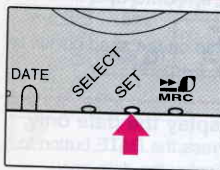

Select the date format.

- The date format changes each time you press the SET button.
- Always use the push-button projection on the strap buckle to push the SET button. (→ p.12)

Date format display

'99 5 20 DATE	Year/month/day
5 20 '99 DATE	Month/day/year
20 5 '99 DATE	Day/month/year



- The selected date format is retained when you replace the battery.

Setting the Date and Time

When you replace the battery or travel abroad, use the procedure below to set or adjust the date and time settings.

- Always use the push-button projection on the strap buckle to push the SELECT and SET buttons. (→ p.12)

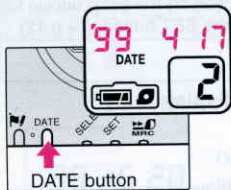

1 Display the date only.

- Press the DATE button to display the date only.
- Skip to step 5 to set the time.

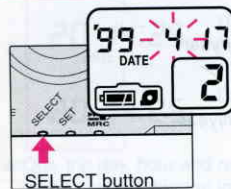

2 Select a date setting.

- Press the SELECT button to select the number you want to change.
→ The selected setting (blinking numbers) changes sequentially from year to month to day.

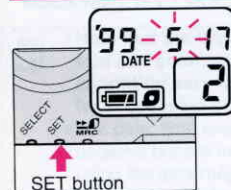

3 Set the date.

- Press the SET button to change the number.
→ Hold the button down for 2 seconds or more to change the setting continuously.

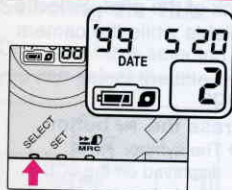

4 Set all the date settings.

- Repeat steps 2 and 3 to set all the date settings.
- When you press the SELECT button and no settings blink, date setting is complete.

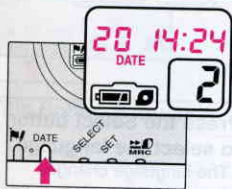

5 Display the date and time.

- Press the DATE button to display the date and time.
- You cannot set the date when the date and time are both displayed.

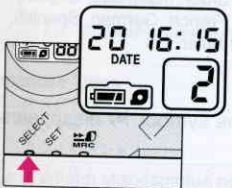

6 Set all the time settings.

- Repeat steps 2 and 3 to set all the time settings.
- If you press the SELECT button and the colon (:) doesn't blink, time setting is complete.



- If you replace the battery, the date and time display on the LCD panel reverts to three blinking dashes ("—") (no date or time imprinting). When this occurs, perform steps 2, 3, 4 and 6 to set the date and time.

Imprinting Titles

You can imprint titles on the back of the print. Select a title from the different titles available while the camera is turned on.

Selecting the Title Language

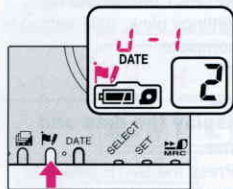

- 1** Press the button.
→ The symbol is displayed on the LCD panel.

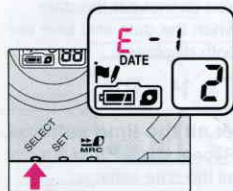

- 2** Press the Select button to select the language.
• The language changes every time you press in this order: Japanese, English, French, German, Spanish, Italian.

Canceling Title Imprinting

- Press the Date button until the symbol disappears from the LCD panel.



- The title imprinting function automatically returns to a date/time setting after one frame is exposed. To continuously imprint the same title, hold down the button for two seconds or longer (until the blinks on the LCD panel).
- **Character size, shape, color, position, and ability to print on both sides may vary according to the individual photo shop.**
- The date and time as set by the Date function are also printed with the title.
- If you want information imprinted on the front of your prints, be sure to check with the photo shop, that they provide this service, before the film is processed.

Selecting the Title

Once you have selected the language for your title, you can select the title.

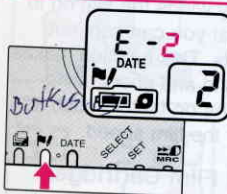

- Press the button.
→ The title number changes every time you press.
• Select the title you want to use, then take the picture.

Title Button Sequence

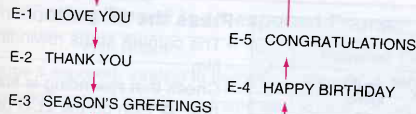

Japanese Titles

- J-1 オメデトウ
- J-2 カンゲキ!
- J-3 カワイイデショ!
- J-4 ヨロシク!
- J-5 ウレシイナ

French Titles

- F-1 JE T'AIME
- F-2 MERCI
- F-3 MEILLEURS VOEUX
- F-4 JOYEUX ANNIVERSAIRE
- F-5 FÉLICITATIONS

Italian Titles

- I-1 TI AMO
- I-2 GRAZIE
- I-3 BUONE FESTE
- I-4 BUON COMPLEANNO
- I-5 CONGRATULAZIONI

German Titles

- D-1 ICH LIEBE DICH
- D-2 DANKE SCHÖN
- D-3 HERZLICHE GLÜCKWÜNSCHE
- D-4 FRÖHLICHE WEIHNACHTEN
- D-5 FROHES NEUES JAHR

Spanish Titles

- ES-1 TE QUIERO
- ES-2 GRACIAS
- ES-3 FELICES PASCUAS
- ES-4 FELIZ CUMPLEAÑOS
- ES-5 FELICIDADES

This camera supports the Film Cartridge Mid-roll Change function, which is one of the major features of the APS format.



If you reload a film cartridge that has been partly used, this useful function automatically winds the film on to the first unexposed frame so that you can continue shooting from that point onwards. This function makes it possible for you to swap around and shoot using multiple film cartridges depending on factors such as the subject, the type of shot, or the film speed.

To Remove an Unfinished Film Cartridge

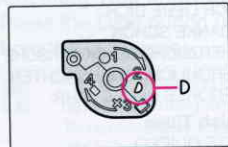
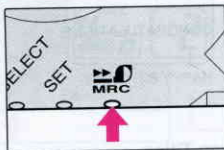
- Always use the push-button projection on the strap buckle to push the  button. (→ p.12)





Press the button.

- The camera starts rewinding the film.
- Check that rewinding is finished (the  icon on the LCD panel is blinking) and then take out the film cartridge.
- The visual exposure indicator on the film cartridge has changed to  (partially exposed).



MRC means Mid Roll Change



- If the  icon and the frame counter start blinking while the film is rewinding, this indicates that a problem has arisen during rewinding. If this occurs, replace the battery and press the  button again. If the camera still fails to operate correctly, switch it off and contact your nearest Canon supplier.

Loading a Partially Used Film Cartridge

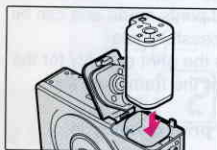

To load a partially used film cartridge, use the procedure described in “Loading the Film Cartridge”. (→ p.16)

- ➔ The camera automatically winds the film on to the first unexposed frame.



Film Winding Speed to Unexposed Frame

Film Status	Required Time
Frame 1 exposed, winding to frame 2	Approx. 11 seconds
Frame 39 exposed, winding to frame 40	Approx. 25 seconds



- In locations exposed to strong radio waves or electromagnetic fields (near a broadcasting tower, etc.), a partially used film cartridge may fail to wind on when loaded. When this occurs, the  icon and the “0” in the frame counter on the LCD panel both blink as a warning. Remove the partially used film cartridge. This problem does not affect the loading of unused film cartridges.
- Note that if you load a partially used film cartridge into a camera that does not support the film cartridge mid-roll change function (such as the Canon ELPH/IXUS), the camera does not advance the film and will assign the fully exposed status to the film cartridge. It will then no longer be possible to take pictures in the unexposed frames.

Setting the Print Quantity

This feature allows you to specify the number of prints (up to nine) of a frame to be produced at one time. This is useful as it saves the trouble of having additional prints made and can be used to avoid getting prints of unsuccessful shots.

Note that you can only set or change the print quantity for the frame about to be shot (next frame) or the frame just shot (previous frame).

- When you load negative film, the print quantity is automatically set to 1 (P-1).
- When you load reversal film, the print quantity is automatically set to 0 (P-0).
- Always use the push-button projection on the strap buckle to push the SELECT and SET buttons. (→ p.12)

Setting the Print Quantity For the Next Frame

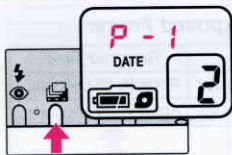

1 Set the print quantity.

- Press the  button.
- Each time you press the button, the setting changes sequentially from P-1, to P-2, through to P-9 and then back to P-0, P-1, etc. (This cycle begins at P-0 when reversal film is used.)
- Hold the button down for 2 seconds or more to cycle continuously through the settings.

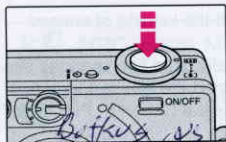

2 Take the picture.

- After you shoot a frame, the print quantity specification reverts to the default setting of 1 print (0 prints for reversal film).

Changing the Print Quantity After Taking a Shot

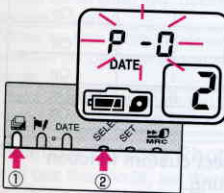

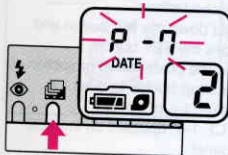

1 Select the mode for specifying the print quantity for the previous frame.

- Press the  button ① and then press the SELECT button ② for at least 2 seconds.
- “P-0” (no prints) blinks on the LCD panel.



2 Set the print quantity.

- Press the  button.
- Each time you press the button , the setting changes sequentially from P-1, to P-2, through to P-9 and then back to P-0, P-1, etc.
- Hold the button down for 2 seconds or more to cycle continuously through the settings.

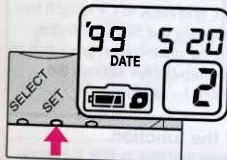

3 Complete the setting.

- Press the SET button.
- The film rewinds 1 frame and the print quantity specification for the previous frame is replaced.
- The date/time display reappears.



- If you switch the camera off before completing the setting, the setting reverts to its previous value.
- If you replace the battery, the date and time display on the LCD panel reverts to three blinking dashes (“—”) and you cannot specify the print quantity. When this occurs, set the date and time before specifying the print quantity. (→ p.40)
- Some processing and printing stores may not support the print quantity specification function. Check with your processing and printing store beforehand.

Setting the Custom Functions

Custom Function No.		Setting	
Realtime Release	CF 1	0	Off
		1	On
Flash Mode Memory	CF 2	0	Off
		1	On
Automatic Rewind	CF 3	0	On
		1	Off

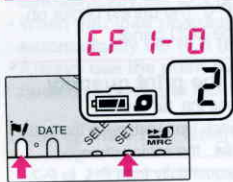

1 Select custom function setting.

- Perform this step with the camera switched off.
- Hold down the button and press the SET button.
- Use the push-button projection on the strap buckle to push the button. (→ p.12)
- "CF 1-0" appears on the LCD panel.

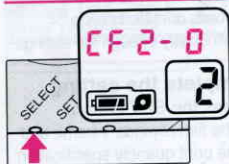

2 Select a function.

- The selected function changes sequentially from CF1 to CF2 to CF3, and back to CF1, each time you press the SELECT button.
- Use the push-button projection on the strap buckle to push the button. (→ p.12)

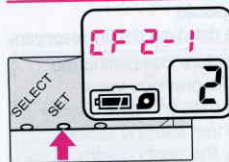

3 Set the function.

- Press the SET button to change the setting display to 1 (function enabled). Press the SET button again to change the setting to 0 (function disabled).
- Press the DATE button or the Main switch when setting is complete.



- The custom function settings are retained even when you switch the camera off and on, replace the film cartridge, or replace the battery.

Usage When Set to 1

Releases the shutter instantly (after 0.03 seconds) when you press the shutter button down fully. Useful for situations where you need an instant camera response.

Stores the flash mode in memory immediately before the camera is switched off. Useful when you always want to set the flash to a particular mode.

Useful for situations where you do not want the sudden sound of the film rewinding. Press the button to start film rewinding.

Realtime Release Photography

- To use this mode, set the custom function CF1 to 1.



1 Set the focus.

- Position the AF frame over your subject and press the shutter button down halfway.
- The camera focuses on the subject with a brief zooming sound and the green indicator lights.
- Keep the shutter button pressed down halfway.



2 Take the picture.



- When the photo opportunity arrives, press the shutter button down fully.
- The shutter is released immediately.



- If you press the shutter button all the way down in a single movement, realtime release does not operate.
- Take care that the distance from the camera to your subject does not change. If the distance changes, start again from step 1.
- Take care not to touch the lens as this may result in the picture being out of focus.
- The and modes use red-eye reduction and should not be used, as shutter release is delayed by approximately 1 second.
- The Focus Lock feature can be used in the same way as for normal photography.

Troubleshooting

In case of trouble check the table below before taking you camera to be repaired.

Problem	Cause	Remedy	Page
The battery check indicator  blinks.	<ul style="list-style-type: none"> • The battery has expired. 	<ul style="list-style-type: none"> • Replace the battery. 	15
The battery check indicator  is not displayed.	<ul style="list-style-type: none"> • No battery is loaded. 	<ul style="list-style-type: none"> • Load a battery. 	15
	<ul style="list-style-type: none"> • The battery is inserted with the wrong polarities. 	<ul style="list-style-type: none"> • Reinsert the battery correctly. 	15
	<ul style="list-style-type: none"> • The battery has completely expired. 	<ul style="list-style-type: none"> • Replace the battery. 	15
The shutter does not release.	<ul style="list-style-type: none"> • The power is turned off. 	<ul style="list-style-type: none"> • Turn the power on. 	18
	<ul style="list-style-type: none"> • The battery has expired. 	<ul style="list-style-type: none"> • Replace the battery. 	15
	<ul style="list-style-type: none"> • A fully exposed film cartridge has been loaded in the camera. 	<ul style="list-style-type: none"> • Remove the film cartridge and load a new one. 	16, 25
	<ul style="list-style-type: none"> • The shutter will be released only after the red-eye reduction lamp is lit for about 1 second. 	<ul style="list-style-type: none"> • Keep pressed until the shutter is released. • Change the flash mode. 	29 27
The camera makes a zooming sound when I press the shutter button down halfway.	<ul style="list-style-type: none"> • Custom function CF1 is set to 1. 	<ul style="list-style-type: none"> • Set custom function CF1 to 0. 	48, 49
The camera is not automatically set to Auto flash mode.	<ul style="list-style-type: none"> • Custom function CF2 is set to 1. 	<ul style="list-style-type: none"> • Set custom function CF2 to 0. 	48
"H" is displayed on the LCD panel.	<ul style="list-style-type: none"> • The self-diagnosis function detected an error. 	<ul style="list-style-type: none"> • Remove the battery from the camera. When "H" disappears from the LCD display, load the battery again. 	15
The film cartridge compartment cover will not open, even when the film counter reads 0	<ul style="list-style-type: none"> • A problem occurred after rewinding. 	<ul style="list-style-type: none"> • Press the  film rewind button. 	25, 44

Problem	Cause	Remedy	Page
The film does not automatically rewind.	<ul style="list-style-type: none"> • Custom function CF3 is set to 1. 	<ul style="list-style-type: none"> • Set custom function CF3 to 0. 	48
The photographs are blurred.	<ul style="list-style-type: none"> • When the shutter was released, the AF light emitter/receptor were blocked. 	<ul style="list-style-type: none"> • Ensure that the AF light emitter/ receptor are not blocked by hair, fingers, etc. 	19
	<ul style="list-style-type: none"> • In self-timer shooting, you stood immediately in front of the camera when pressing the shutter button. • The camera moved when the shutter button was pressed (camera shake). • The AF light emitter/receptor may be dirty. 	<ul style="list-style-type: none"> • Make sure you do not stand immediately in front of the camera when pressing the shutter button. • Press the shutter button gently. • Wipe them clean. 	35 22 19

Questions and Answers

Q1 Can conventional 135 (35mm) film be used?

A1 No it cannot be used. Use IX240 film cartridges.

Q2 Can slide (reversal) film be used with this camera?

A2 Yes it can.

Q3 What is ISO?

A3 The ISO number indicates the film's sensitivity to light in numerical terms. The higher the number, the more sensitive the film is to light.

Q4 The picture was taken with date imprinting, but it doesn't appear on the index print. Why is this?

A4 The date and time are recorded on the film surface magnetically. This data is read electronically and imprinted during the printing process. This is why the date and time data may not appear on the index print sheets.

Q5 When converted to a 35mm camera, what is this camera's 23-46 mm focusing distance equivalent to?

A5 Approximately 29-58 mm (for H prints).

Specifications

Type: IX240 fully-automatic lens-shutter AF camera with built-in zoom lens and magnetic IX functions

Image Size: 16.7 × 30.2 mm

Lens: Canon 23-46 mm f/4.2-5.6 lens Active/passive hybrid autofocus

Shooting distance: 0.45 m to ∞

Shutter: Combination aperture and program electromagnetically driven shutter

Viewfinder: Real-image zoom viewfinder

Coverage: Approx. 86%

Viewfinder Information: Picture frame, AF frame, Close-up frame

Viewfinder Eyepiece:

Green indicator	Combination camera ready indicator and proximity warning
Orange indicator	Combination flash ready indicator and camera shake warning

Film Cartridge Loading: Automatic (automatic blank film advance)

Film Advance: Automatic

Film Rewinding: Automatic at end of film; mid-roll rewind possible

Frame Counter: Counts up during film advance and counts down during film rewinding

Self-Timer: Electronically controlled 10 sec. delay timer operated from the shutter button. The red-eye reduction lamp on the camera body front flashes during operation and the frame counter counts down the remaining seconds.

Metering Range:

AUTO and Flash ON modes:

Wide-angle: 1/800 at f/18 to 1/60 at f/4.2

Telephoto: 1/900 at f/34 to 1/90 at f/5.6

Flash OFF and Slow Synchro modes:

Wide-angle: 1/800 at f/18 to 2 sec. at f/4.2

Telephoto: 1/900 at f/34 to 2 sec. at f/5.6

Exposure Compensation: +1.5 step automatic exposure compensation in backlit conditions if required

Film Speed: ISO 25-10000, set automatically in 1/3-step increments

Built-in Flash: Internal flash fires automatically in low light and backlit conditions

Flash Range:

ISO 100 Wide-angle: 0.45 to 3.0 m (1.5 to 9.8 ft.);

Telephoto: 0.45 to 2.2 m (1.5 to 7.2 ft.)

ISO 200 Wide-angle: 0.45 to 4.2 m (1.5 to 13.8 ft.);

Telephoto: 0.45 to 3.1 m (1.5 to 10.2 ft.)

(using color print film)

Flash Recycling Time: Approx. 6 seconds (with new battery)

Flash Mode Selection: Using flash mode button

- ① Auto flash with red-eye reduction: Fires automatically in low light and backlit conditions
- ② Auto flash with red-eye reduction: Fires automatically in low light and backlit conditions
- ③ Flash ON: Fires for all shots
- ④ Flash OFF: Never fires
- ⑤ Slow Synchro: Fires for all shots (with red-eye reduction)

Imprinting Function:

Type: Automatic calendar with built-in LCD panel and quartz digital clock (programmed up to 2029 with automatic correction for leap years)

Imprinted Data: Date only/date + time, and title (5 selections in 6 languages)

Character types: Dependent on processing lab specifications

Imprinting color: Dependent on processing lab specifications

- Custom Functions:**
- ① Realtime Release setting
 - ② Flash mode memory setting
 - ③ Automatic film rewind setting

Power Supply: One lithium battery (CR2, 3V)

Number of Shots: Approx. 10 cartridges of 25-exposure film (normal temperature with 50% flash use)

Dimensions (W × H × D): 87 × 57 × 24.5 mm (3.4 × 2.2 × 1.0 in)

Weight: 170 g (6.0 oz.) (excluding battery)

Remote Control Function (using RC-5, option):

Dedicated remote control system using infrared light and operated by the transmitter button. The shutter releases after a 2-second delay.

Operating range: Up to approx. 5 m (16.5 ft.)

Battery life: Approx. 6000 times

- All data are based on Canon's Standard Test Method.
- Subject to change without notice